



# Installation instructions for piezoresistive OEM pressure sensors and OEM pressure transmitters (L/LC/LD series)

## Handling instructions

- The metal diaphragm is very thin (approx. 20 µm), so do not touch it with hard or sharp objects under any circumstances. Even slight deformations can affect the pressure signal!
- In the event of pressure overloads, please note that even pressure pulses  $< 0,1 \mu\text{s}$  are “detected” by the pressure sensor chip. Short, high pressure peaks can cause the sensor chip to break.

## Installation instructions

- During installation, make sure that no mechanical stress is transferred to the sensor. When designing the axial and radial gap, the entire operating temperature range must be taken into account. We generally recommend three installation methods (see following page).

1. “Recessed” installation
2. “Flush” installation
3. Installation “with circlip”

- To minimise friction during installation, moisten the O-rings slightly with a suitable grease (e.g. Dow Corning® High Vacuum Grease).  
**Caution:** Do not use any grease for O<sub>2</sub> applications!
- Do not bend the connection pins directly onto the glass feedthrough because the glass may break, which means that the sensor may no longer be sealed. The electrical connection must not be exposed to mechanical stress (tension, pressure, torsion).
- Only clean the diaphragm with an appropriate solvent. With larger pressure ranges (from 100 bar), the diaphragm can also be cleaned using low-intensity ultrasound.
- Sufficient time must be allowed for the O-ring to bed into the installation opening. Make sure that the O-ring, and the support ring if required, are not moved during the bedding-in phase (see also the detail drawing of the relevant method on the following page).
- In the event of pressure loads of  $> 200$  bar, the support must always be installed on the glass feedthrough.

### “Recessed” installation

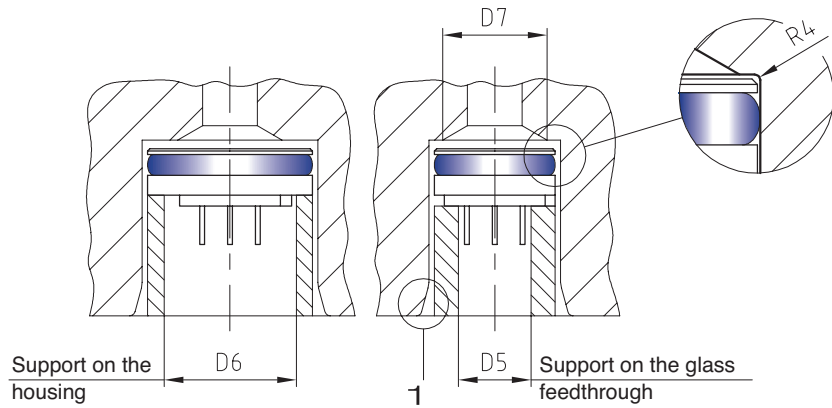

### “Flush” installation

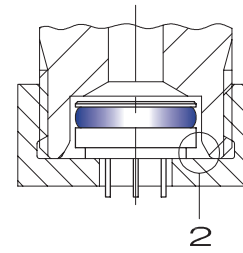

### Installation “with circlip”

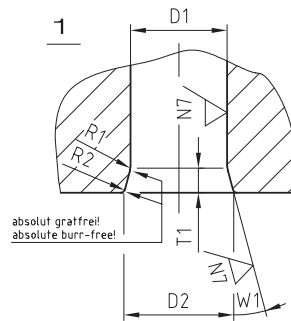
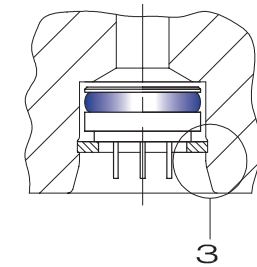

N7 = Ra1.6 μm

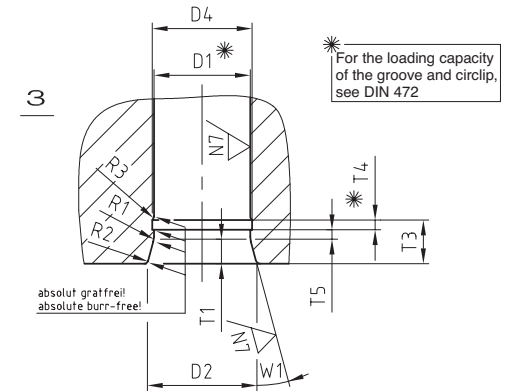
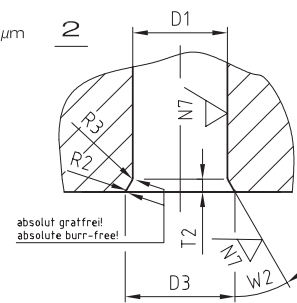

Series / type	D1		D2	D3	D4	D5 on gl.f.thr.	D6 on the housing	D7	R1	R2	R3	R4	T1	T2	T3	T4	T5	W1	W2
	≤ 100 bar	> 100 bar																	
3 L	ø 9,5F8	ø 9,5G7	ø 11	ø 11,2	ø 10,4H11	≥ ø 6,6	—	≥ ø 7,6	2	0,5	max. 0,5	max. 0,2	2,8	1,5	≥ 5	1,1H13	(1,1)	15°	30°
4 L / 4 LC / 4 LD	ø 11F8	ø 11G7	ø 12,5	ø 12,7	ø 11,4H11	≥ ø 6,6	—	≥ ø 9,5	2	0,5	max. 0,5	max. 0,2	2,8	1,5	≥ 5	1,1H13	(1,1)	15°	30°
4 L / 4 LD with support ring	—	ø 11G7	ø 12,5	ø 12,5	—	≥ ø 6,6	—	≥ ø 9,5	2	0,5	—	max. 0,2	2,8	2,8	—	—	—	15°	15°
5 L	ø 12F8	ø 12G7	ø 13,5	ø 13,7	ø 12,5H11	≥ ø 6,6	—	≥ ø 9,5	2	0,5	max. 0,5	max. 0,2	2,8	1,5	≥ 5	1,1H13	(1,1)	15°	30°
6 L / 6 LC / 6 LD	ø 13F8	ø 13G7	ø 14,5	ø 14,7	ø 13,6H11	≥ ø 6,6	≥ ø 11,5	≥ ø 10	2	0,5	max. 0,5	max. 0,2	2,8	1,5	≥ 5	1,1H13	(1,1)	15°	30°
6 L HP / 6 LC HP / 6 LD HP	—	ø 13G7	ø 14,5	—	—	≥ ø 6,6	—	≥ ø 10	2	0,5	—	max. 0,2	2,8	—	—	—	—	15°	—
7 L / 7 LC / 7 LD	ø 15F8	ø 15G7	ø 16,5	ø 16,7	ø 15,7H11	≥ ø 6,6	≥ ø 12	≥ ø 12	2	0,5	max. 0,5	max. 0,2	2,8	1,5	≥ 5	1,1H13	(1,1)	15°	30°
7 L HP / 7 LC HP / 7 LD HP	—	ø 15G7	ø 16,5	—	—	≥ ø 6,6	—	≥ ø 12	2	0,5	—	max. 0,2	2,8	—	—	—	—	15°	—
9 L / 9 LC / 9 LD	ø 19F8	ø 19G7	ø 20,5	—	ø 20H11	≥ ø 6,6	≥ ø 12	≥ ø 16	2	0,5	max. 0,5	max. 0,2	2,8	—	≥ 5,5	1,1H13	(1,1)	15°	—
10 L / 10 LC / 10 LD	ø 19F8	ø 19G7	ø 20,5	ø 20,7	ø 20H11	—	≥ ø 15	≥ ø 15	2	0,5	max. 0,5	max. 0,2	2,8	1,5	≥ 5	1,1H13	(1,1)	15°	30°